



2-port valves
VVP47.10-0.25 to VVP47.20-4.0



3-port valves
VXP47.10-0.25 to VXP47.20-4.0



3-port valves with bypass
VMP47.10-0.25 to VMP47.15-2.5

Acvatix™

2-port and 3-port terminal unit valves PN16

VVP47..
VXP47..
VMP47..

- Bronze valve body CC491K (Rg5)
- DN 10, DN 15 and DN 20
- k_{vs} 0.25 to 4 m³/h
- Flat seal male threaded connections G..B to ISO 228-1 for
 - Screwed fittings ALG.. (available from Siemens)
 - SERTO SO 00021.. compression fittings (available from suppliers to the trade)
 - Screwed fittings for welded connections (available from suppliers to the trade)
- Manual adjuster
- Can be combined with SSP.. / SFP.. electromotoric actuators or STP.. / STS61.. thermal actuators

Use

- For use in ventilation and air conditioning systems for water-side terminal unit control in closed circuits, e.g. for induction units, fan coil units, small re-heaters and small re-coolers.
 - 2-pipe systems with 1 heat exchanger for heating and cooling
 - 4-pipe systems with 2 separate heat exchangers for heating and cooling
- In closed-circuit zone heating systems, e.g. for:
 - Separate floors in a building
 - Apartments and individual rooms
- The VXP47..S 3-port valves together with SFP.. actuators are specially suited for changeover applications where small leakage rates are required.

Type summary

VVP47.. 2-port	VXP47.. 3-port	VMP47.. 3-port with bypass	DN	k_{vs} A → AB [m ³ /h]	$k_{vs}^{1)}$ B → AB [m ³ /h]
VVP47.10-0.25	VXP47.10-0.25	VMP47.10-0.25	10	0.25	0.18
VVP47.10-0.4	VXP47.10-0.4	VMP47.10-0.4		0.40	0.28
VVP47.10-0.63	VXP47.10-0.63	VMP47.10-0.63		0.63	0.44
VVP47.10-1	VXP47.10-1	VMP47.10-1		1.00	0.70
VVP47.10-1.6	VXP47.10-1.6	VMP47.10-1.6		1.60	1.12
VVP47.15-2.5	VXP47.15-2.5	VMP47.15-2.5	15	2.50	1.75
VVP47.20-4	VXP47.20-4		20	4.00	2.80

¹⁾ Applies only to 3-port version

k_{vs} = nominal flow rate of cold water (5...30 °C) through the fully opened valve (H_{100}) at a differential pressure of 100 kPa (1 bar)

Accessories

Prod. No.	Stock no.	Description
ALG..2	ALG..2	Set of 2 fittings with threaded connections for 2-port valves or 3-port valves with bypass, consisting of: 2 union nuts, 2 discs and 2 flat seals ALG..3B are brass fittings, for media temperatures up to 100 °C.
ALG..2B	S55846-Z1..	
ALG..3	ALG..3	Set of 3 fittings with threaded connections for 3-port valves, consisting of: 3 union nuts, 3 discs and 3 flat seals ALG..3B are brass fittings, for media temperatures up to 100 °C.
ALG..3B	S55846-Z1..	

Ordering

Please give valve and the required ALG.. screwed fittings. The ALG.. screwed fittings and the SSP..., SFP..., STP... and STS61.. actuators must be ordered as separate items.

Example:

Product number	Stock number	Description	Quantity
VXP47.10.1	VXP47.10.1	3-port Terminal Unit Valve PN16	4
ALG133	ALG133	Screwed Fittings	4

For 3-port valves with bypass VMP47.. order two sets of ALG..2 or ALG..2B screwed fittings.

Delivery

Valves, actuators and fittings are packed and supplied separately.

Equipment combinations

Valves	electromotoric actuators				thermal actuators			
	SSP..		SFP..		STP..		STS61.. ¹⁾	
	Δp_{max} [kPa]	Δp_s [kPa]	Δp_{max} [kPa]	Δp_s [kPa]	Δp_{max} [kPa]	Δp_s [kPa]	Δp_{max} [kPa]	Δp_s [kPa]
VVP47.10-0.25...0.4	400	1000	400	1000	400	700	400	700
VVP47.10-0.63...1		500		500				
VVP47.10-1.6	300	300	300	300	150	150	150	150
VVP47.15-2.5								
VVP47.20-4	175	175	175	175	100	100	100	100
VXP47.10-0.25...0.4	400		400		400		400	
VXP47.10-0.63...1					250		250	
VXP47.10-1.6	300		300		150		150	
VXP47.15-2.5								
VXP47.20-4	175		175		100		100	
VMP47.10-0.25...0.4	400		400		400		400	
VMP47.10-0.63...1					250		250	
VMP47.10-1.6	300		300		150		150	
VMP47.15-2.5								
VMP47.20-4	175		175		100		100	
Data sheet	N4864		N4865		N4878		N4880	



¹⁾ After a power failure or switching off the operating voltage the control path A → AB of the valve opens.

Δp_{max} = maximum permissible differential pressure across the control path of the valve valid for the entire actuating range of the motorized valve

Δp_s = maximum permissible differential pressure (close of pressure) at which the motorized valve will close securely against the pressure

Overview of actuators

Actuator	Type of actuator	Operating voltage	Positioning signal	Positioning time	Positioning force
SSP31..	Electromotoric	AC 230 V	3-position	150 s	160 N
SSP81..		AC 24 V		43 s	
SSP81.04		AC / DC 24 V	DC 0...10 V	34 s	
SSP61..			DC 5...7.5 V		
SSP61P		AC / DC 24 V	2-position	10 s	135 N
SFP21/18		AC 230 V			
SFP81/18	AC 24 V	Thermal	2-position	180 s	105 N
STP21..	AC 230 V				
STP71..	AC / DC 24 V		2-position / PDM	70 s ¹⁾	105 N
STP72E..	AC 24 V				
STS61..	AC 24 V	DC 0...10 V			

¹⁾ 80 s delay time after standby mode
PDM = Pulse-Duration-Modulation

Sizing

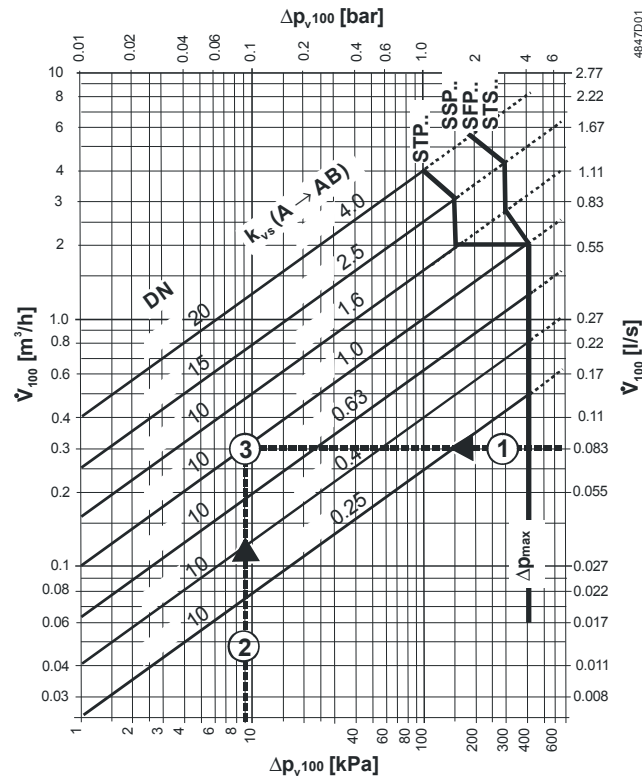

Example:

- $\dot{V}_{100} = 0.083$ l/s
- $\Delta p_{v,100} = 9$ kPa
- Required K_{vs} -value = 1.0 m³/h

$\Delta p_{v,100}$ = differential pressure across the fully open valve and control path A → AB by a volume flow \dot{V}_{100}

\dot{V}_{100} = volume flow through the fully open valve (H_{100})

Δp_{max} = maximum permissible differential pressure across the valve's control path, valid for the entire actuating range of the motorized valve

100 kPa = 1 bar ≈ 10 mWC

1 m³/h = 0.278 l/s water at 20 °C

Valve characteristics

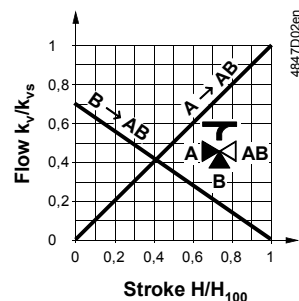

With valve types VXP47../VMP47.., the k_{vs} values in bypass B represent only 70 % of the k_{vs} value in the straight-through control path, A → AB.

This compensates for the flow resistance of the heat exchanger or radiator, so keeping the overall flow rate, \dot{V}_{100} as constant as possible.

Mechanical design



- Combined disc / plug flow restrictor
- Seat ring embedded in through-port A → AB
- Seat machined into bypass B → AB.
- Continuously lubricated sealing rings
- Conical return springs, for more compact valve construction

Engineering notes

Also refer to "Mounting notes" and "Commissioning", page 5.

The 2-port valves should preferably be installed in the return, where the stem seal will be exposed to lower temperatures.

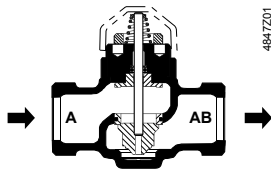
Recommendation: A strainer should be fitted upstream of the valve. This increases reliability.

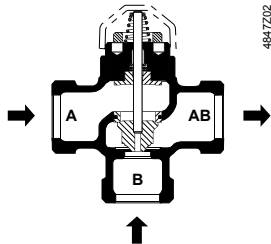
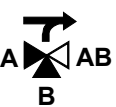
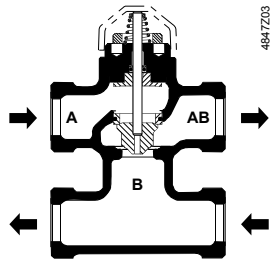
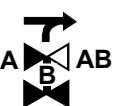
Valve construction	Valve series	Valve flow in control mode			Valve stem	
		Inlet A	Inlet B	Outlet AB	Retracted	Extended
2-port valves 	VVP47.. 	variable		variable	A → AB opens	A → AB closes
3-port valves 	VXP47.. 	variable	variable	constant	A → AB opens B → AB closes	A → AB closes B → AB opens
3-port valves with bypass 	VMP47.. 	variable	variable	constant	A → AB opens B → AB closes	A → AB closes B → AB opens

Warning

The direction of flow **MUST** be as indicated by the arrow, i.e. only from A → AB and B → AB.

The 3-port valve types VXP47.. and VMP47.. may only be used in mixing applications.

Mounting notes

Orientation

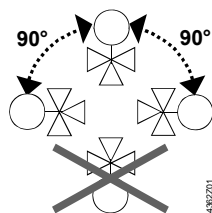

The specified direction of flow must be observed in all cases, also refer to "Engineering notes", page 4.

The valves are delivered in multiple packs; Mounting Instructions 74 319 0301 0 are enclosed with the packaging.

The valve and actuator can be easily assembled on site. There is no need for special tools or calibration.

AL50 supporting ring

The AL50 supporting ring must be put into position before mounting the actuator SFP.. onto the valve. Only the equipment combination V..P47.. and SFP.. requires supporting ring AL50.

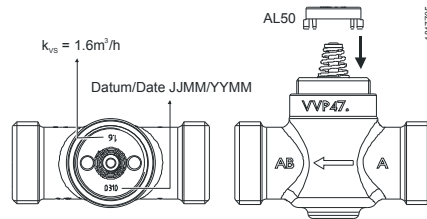

Commissioning



Commission the valve only if the manual knob or actuator have been mounted correctly.

Manual adjustment

The straight-through control path A → AB can be opened either electrically via the actuator, or by adjustment with the manual button. In the case of 3-port valves, this throttles or closes bypass B.

Maintenance



V..P47.. valves require no maintenance.

When doing service work on the valve / actuator:

- Deactivate the pump and turn off the power supply
- Close the shutoff valves
- Fully reduce the pressure in the piping system and allow pipes to completely cool down

If necessary, disconnect the electrical wires.

Before putting the valve into operation again, make certain the manual knob or the actuator is correctly fitted.

Stem sealing gland

The stem sealing gland cannot be exchanged. In the case of leakage, the entire valve must be replaced. Contact your local office or branch.

Disposal



The valve must be dismantled and separated into its various constituent materials before disposal.

Legislation may demand special handling of certain components, or it may be sensible from an ecological point of view.

Current local legislation must be observed.

Warranty

The technical data supplied for these valves is valid only for valves used in conjunction with the actuators listed under "Equipment combinations", page 2.

Use with third-party actuators invalidates any warranty offered by Siemens Switzerland Ltd / HVAC Products.

Technical data

Operating data	PN class	PN 16 to EN 1333
	Permissible operating pressure	1600 kPa (16 bar)
	Valve characteristic	
	Path A → AB	linear
	Bypass B → AB	linear
	Leakage rate	to DIN EN 1349
	Path A → AB	0...0.05 % of k_{vS} value
	Bypass B → AB	0...0.05 % of k_{vS} value
	Permissible media	chilled water, low-temperature hot water and water with frost protection additives recommendation: water should be treated as specified in VDI 2035
	Temperature of medium	1...110 °C, or max. 120 °C for short periods ¹⁾
	Rangeability S_v	> 50 as in VDI 2173
Nominal stroke	2.5 mm	
Norms and standards	Pressure Equipment Directive	PED 97/23/EC
	Pressure Accessories	as per article 1, section 2.1.4
	Fluid group 2	without CE-marking as per article 3, section 3 (sound engineering practice)
	Environmental compatibility	ISO 14001 (Environment) ISO 9001 (Quality) SN 36350 (Environmentally compatible products) RL 2002/95/EG (RoHS)
Materials	Valve body	bronze CC491K (Rg5)
	Stem	stainless steel
	Plug, seat ring, gland	brass
	Stem seal	EPDM O-rings
Dimensions / weight	Dimensions	refer to "Dimensions", page 7
	Threaded connections	
	Valve	G..B to ISO 228-1
	Screwed fittings	R/Rp.. to ISO 7-1, G.. to ISO 228-1
	Actuator connection	M30 x 1.5
Weight	refer to "Dimensions", page 7	
Accessories	ALG..2, ALG..3 screwed fittings (supplier: Siemens)	nut, nipple and flat seal for steel pipes with gas-pipe threads
	SERTO SO 00021.. screwed fittings (available from suppliers to the trade)	nut and compression fitting for seamless copper and mild-steel piping
	Welded fittings (available from suppliers to the trade)	for copper and steel piping

¹⁾ ALG..B fittings for media temperatures upto 100 °C

S_v = rangeability k_{vS} / k_{vR}

k_{vS} = nominal flow rate of chilled water (5...30 °C) through the fully opened valve (H_{100}) at a differential pressure of 100kPa (1bar).

k_{vR} = the lowest value for k_v at which the flow characteristic tolerance is still maintained, at a differential pressure of 100kPa (1 bar)

Dimensions

2-port valves VVP47..

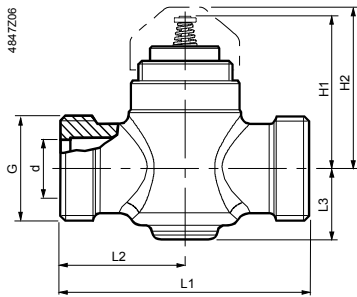

3-port valves VXP47..

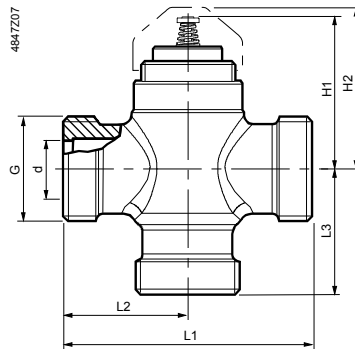

3-port valves with bypass VMP47..

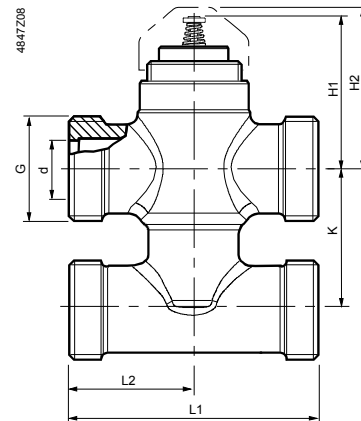

Product number	DN	G [Inch]	d [mm]	H1 [mm]	H2 [mm]	L1 [mm]	L2 [mm]	L3 [mm]	Weight [kg]
VVP47.10-0.25...1.6	10	G½B	10.5	46	≈ 49	60	30	19	0.32
VVP47.15-2.5	15	G¾B	14	46	≈ 49	65	32.5	19	0.34
VVP47.20-4	20	G1B	20	49	≈ 52	80	40	23	0.44



Product number	DN	G [Inch]	d [mm]	H1 [mm]	H2 [mm]	L1 [mm]	L2 [mm]	L3 [mm]	Weight [kg]
VXP47.10-0.25...1.6	10	G½B	10.5	46	≈ 49	60	30	30	0.32
VXP47.15-2.5	15	G¾B	14	46	≈ 49	65	32.5	32.5	0.37
VXP47.20-4	20	G1B	20	49	≈ 52	80	40	40	0.5

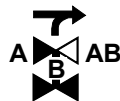

Product number	DN	G [Inch]	d [mm]	H1 [mm]	H2 [mm]	K [mm]	L1 [mm]	L2 [mm]	Weight [kg]
VMP47.10-0.25...1.6	10	G½B	10.5	46	≈ 49	40	60	30	0.4
VMP47.15-2.5	15	G¾B	14	46	≈ 49	40	65	32.5	0.48

Sets of screwed fittings with flat seal: Set of 2

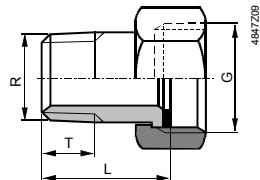

Prod. no. /stock no.	Prod. No.	Stock no.	Connection pipeside	G [Inch]	Rp [Inch]
ALG132			External thread	G ½	R ⅝
ALG142			External thread	G ¾	R 1 ½

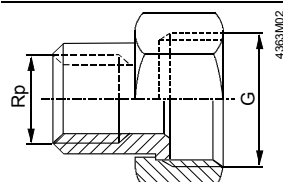

ALG122			Internal thread	G ¾	Rp ⅝
ALG152	ALG152B	S55846-Z100	Internal thread	G 1	Rp 1 ½

Set of 3

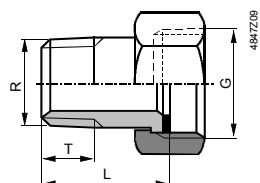

Prod. no. /stock no.	Prod. No.	Stock no.	Connection pipeside	G [Inch]	Rp [Inch]
ALG133			External thread	G ½	R ⅝
ALG143			External thread	G ¾	R 1 ½

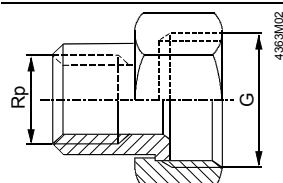

ALG123			Internal thread	G ¾	Rp ⅝
ALG153	ALG153B	S55846-Z101	Internal thread	G 1	Rp 1 ½

Compression fittings

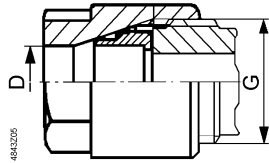

SERTO SO 00021..

available from suppliers to the trade



Overview fitting combinations

ALG... type	for valve type	DN	G [inch]	R [inch]	Rp [inch]	L [mm]	T [mm]	Type SERTO SO 00021.. www.serto.com	D [mm]
ALG132	VVP47.10-0.25...1.6	10	G ½	R ¾		≈ 24	≈ 9	SO 00021-12-1/2"	12
ALG133	VXP47.10-0.25...1.6							SO 00021-14-1/2"	14
2 x ALG132	VMP47.10-0.25...1.6							SO 00021-15-1/2"	15
ALG142	VVP47.15-2.5	15	G ¾	R ½		≈ 29.5	≈ 12	SO 00021-17-3/4"	17
ALG143	VXP47.15-2.5							SO 00021-18-3/4"	18
2 x ALG142	VMP47.15-2.5								
ALG152	VVP47.20-4	20	G 1		Rp ½	≈ 23	≈ 13		
ALG152B									
ALG153	VXP47.20-4								
ALG153B									

¹⁾ SO 00021-17.. and SO 00021-18 on request

DN = Nominal size

G = Valve thread (internal cylindrical)

D = External diameter for seamless copper and mild-steel piping

Revision numbers

Product number	Valid from manufacturing date	Product number	Valid from manufacturing date	Product number	Valid from manufacturing date
VVP47..	0809 ¹⁾	VXP47..	0809 ¹⁾	VMP47..	0809 ¹⁾

¹⁾ MMY = Month, Year of manufacturing